

NOTES:

1. MATERIAL: AISI 304 STAINLESS STEEL

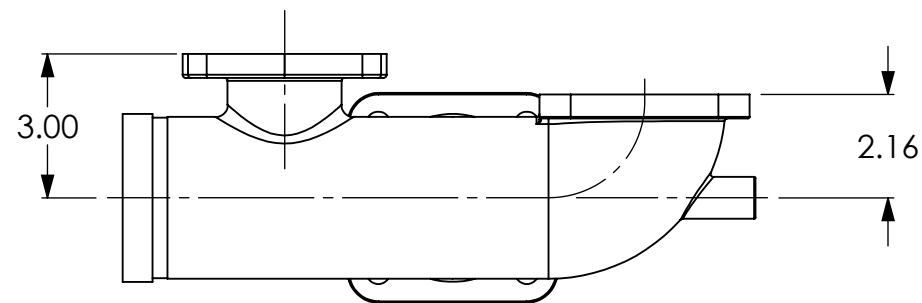
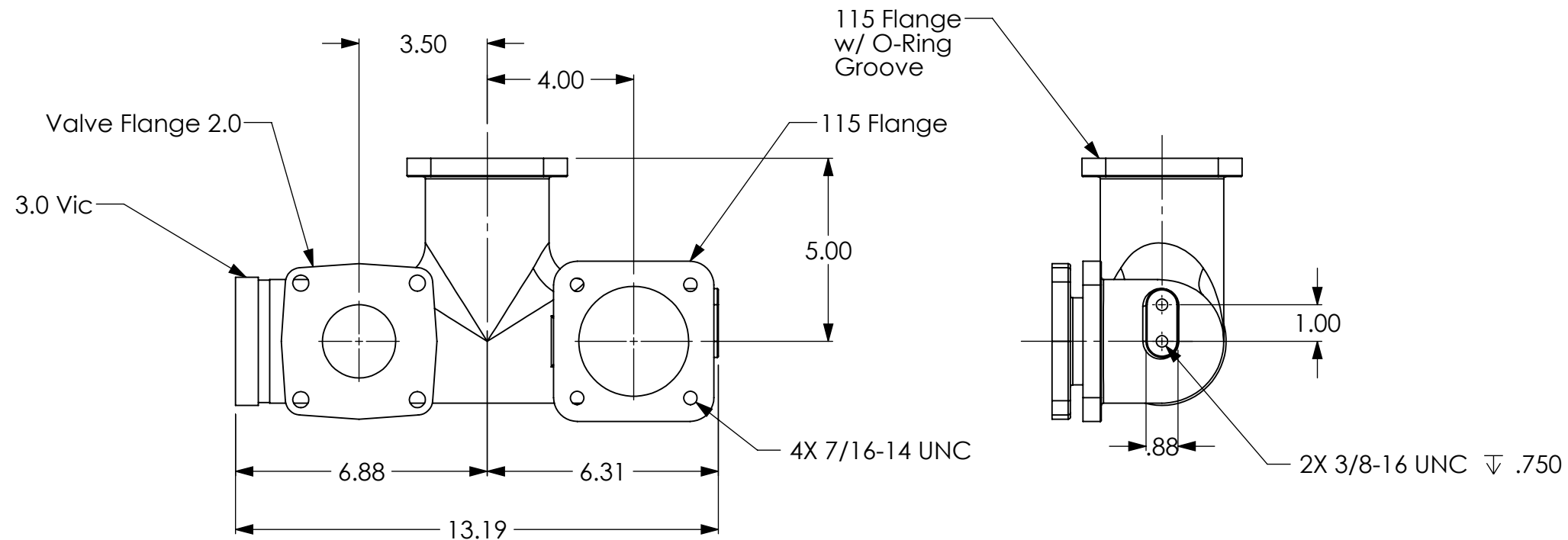
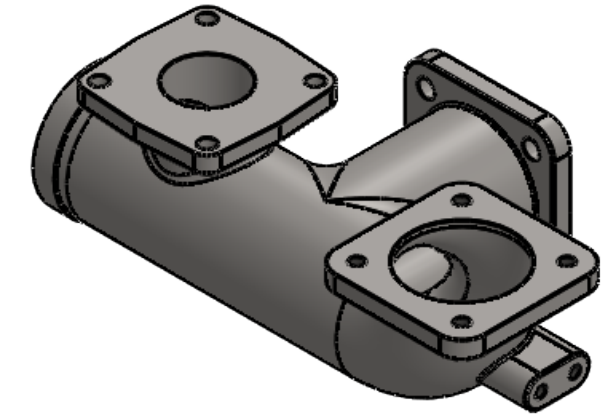

REVISIONS		
REV.	DATE	DESCRIPTION
A	12/11/2019	Initial Release
B	6/15/2020	Added clarification to tolerances on dimensions from 115 flange to victaulic.

<p>DRAWING NOTES UNLESS OTHERWISE SPECIFIED</p> <ol style="list-style-type: none"> <li>All dimensions are in inches.</li> <li>Do not scale drawing.</li> <li>Decimal Tolerance X.XX = +/- 0.01</li> <li>Decimal Tolerance X.XXX = +/- 0.005</li> <li>Fractional Tolerance X/X = +/- 1/16</li> <li>Angle Tolerance: 0.5 degrees</li> </ol>
<p>APPROXIMATE WEIGHT (LBS)</p> <p>13.487</p>
<p>THE INFORMATION CONTAINED IN THIS DRAWING IS THE SOLE PROPERTY OF FIRE PROGRAMS, LLC. ANY REPRODUCTION IN PART OR AS A WHOLE WITHOUT THE WRITTEN PERMISSION OF FIRE PROGRAMS, LLC IS PROHIBITED.</p>

<p>FirePrograms</p> <p>6405 SW 38th St, Bldg 200 Ocala, FL 34474 Phone: 800.327.7638 www.fireprograms.com</p>									
<p>TITLE</p> <p>Cstg Foam Manifold LS</p>									
<p>DRAWING NUMBER</p> <p>500236</p>	<table border="1"> <tr> <td>REV</td> <td>SHEET SCALE</td> </tr> <tr> <td>B</td> <td>1:4</td> </tr> <tr> <td>DATE</td> <td>SHEET</td> </tr> <tr> <td>6/15/2020</td> <td>1 OF 1</td> </tr> </table>	REV	SHEET SCALE	B	1:4	DATE	SHEET	6/15/2020	1 OF 1
REV	SHEET SCALE								
B	1:4								
DATE	SHEET								
6/15/2020	1 OF 1								