

NOTES:

1. MATERIAL: AISI 304 STAINLESS STEEL.

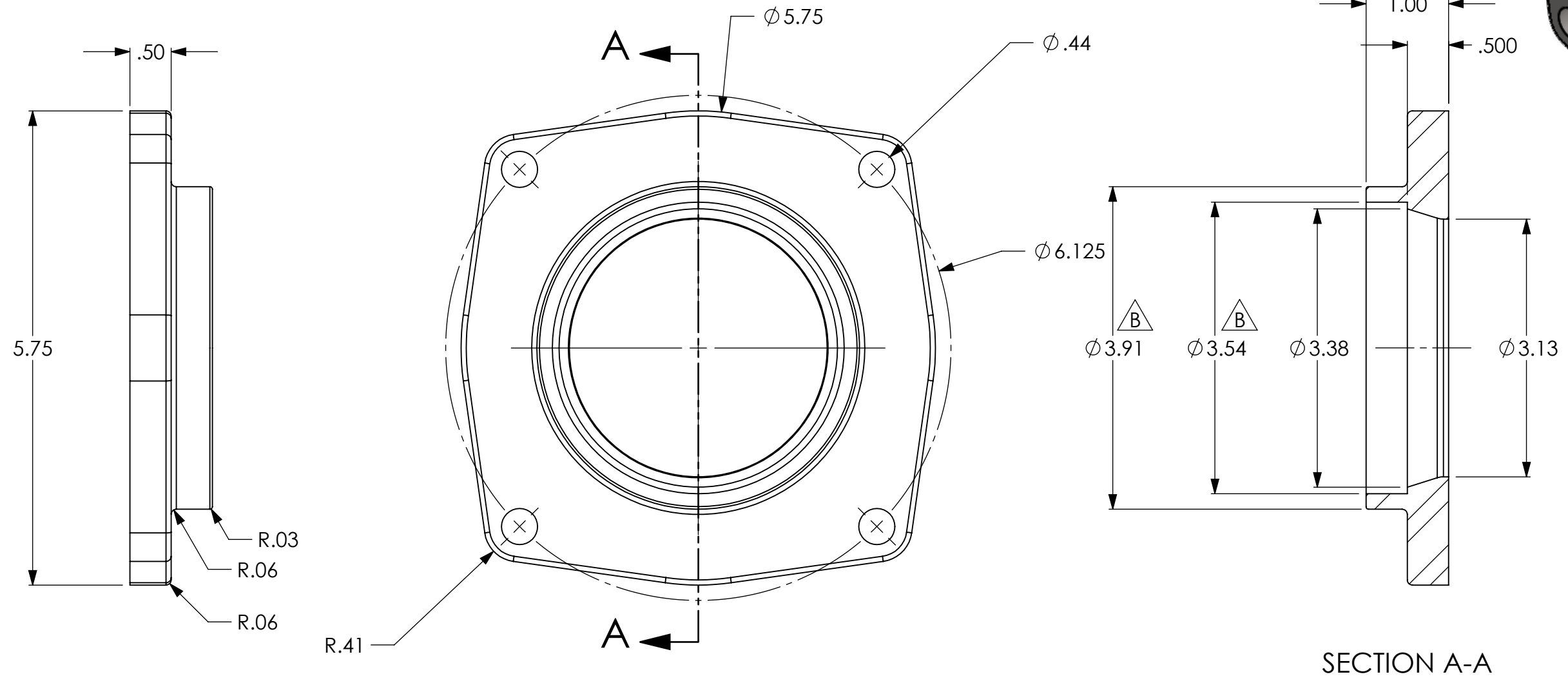
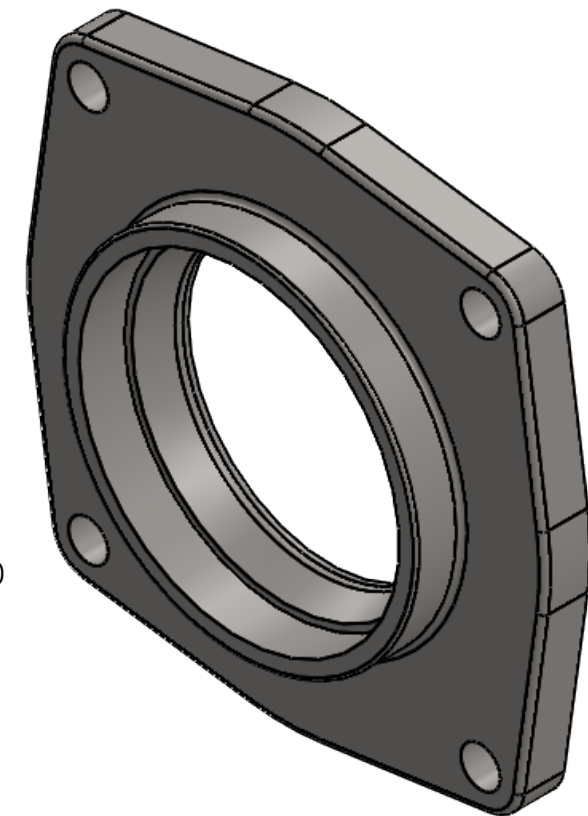

SECTION A-A

REVISIONS		
REV.	DATE	DESCRIPTION
A	11/22/2017	Initial Release
B	1/23/2018	Increase shoulder height. Reduce opening diameter. Change opening tolerance to +/- .005.

DRAWING NOTES UNLESS OTHERWISE SPECIFIED
 1. All dimensions are in inches.
 2. Do not scale drawing.
 3. Decimal Tolerance X.XX = +/- 0.01
 4. Decimal Tolerance X.XXX = +/- 0.005
 5. Fractional Tolerance X/X = +/- 1/16
 6. Angle Tolerance: 0.5 degrees

APPROXIMATE WEIGHT (LBS)
 3.30

THE INFORMATION CONTAINED IN THIS DRAWING IS THE SOLE PROPERTY OF FIRE PROGRAMS, LLC. ANY REPRODUCTION IN PART OR AS A WHOLE WITHOUT THE WRITTEN PERMISSION OF FIRE PROGRAMS, LLC IS PROHIBITED.

FirePrograms
SOFTWARE

6405 SW 38th St, Bldg 200
 Ocala, FL 34474
 Phone: 800.327.7638
 www.fireprograms.com

TITLE
Cstg Vlv 3.0 x Pipe 3.0 Weld

DRAWING NUMBER
500186

REV B	SHEET SCALE 1:1.5
DATE 1/23/2018	SHEET 1 OF 1