

NOTES:

1. MATERIAL: STEEL WITH YELLOW ZINC CHROMATE FINISH.

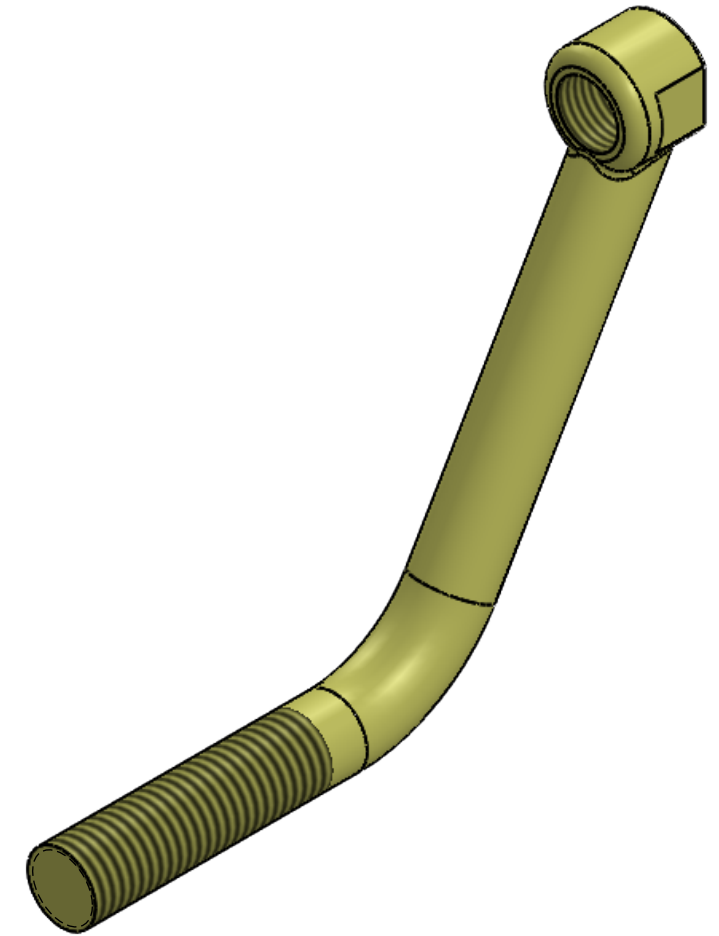
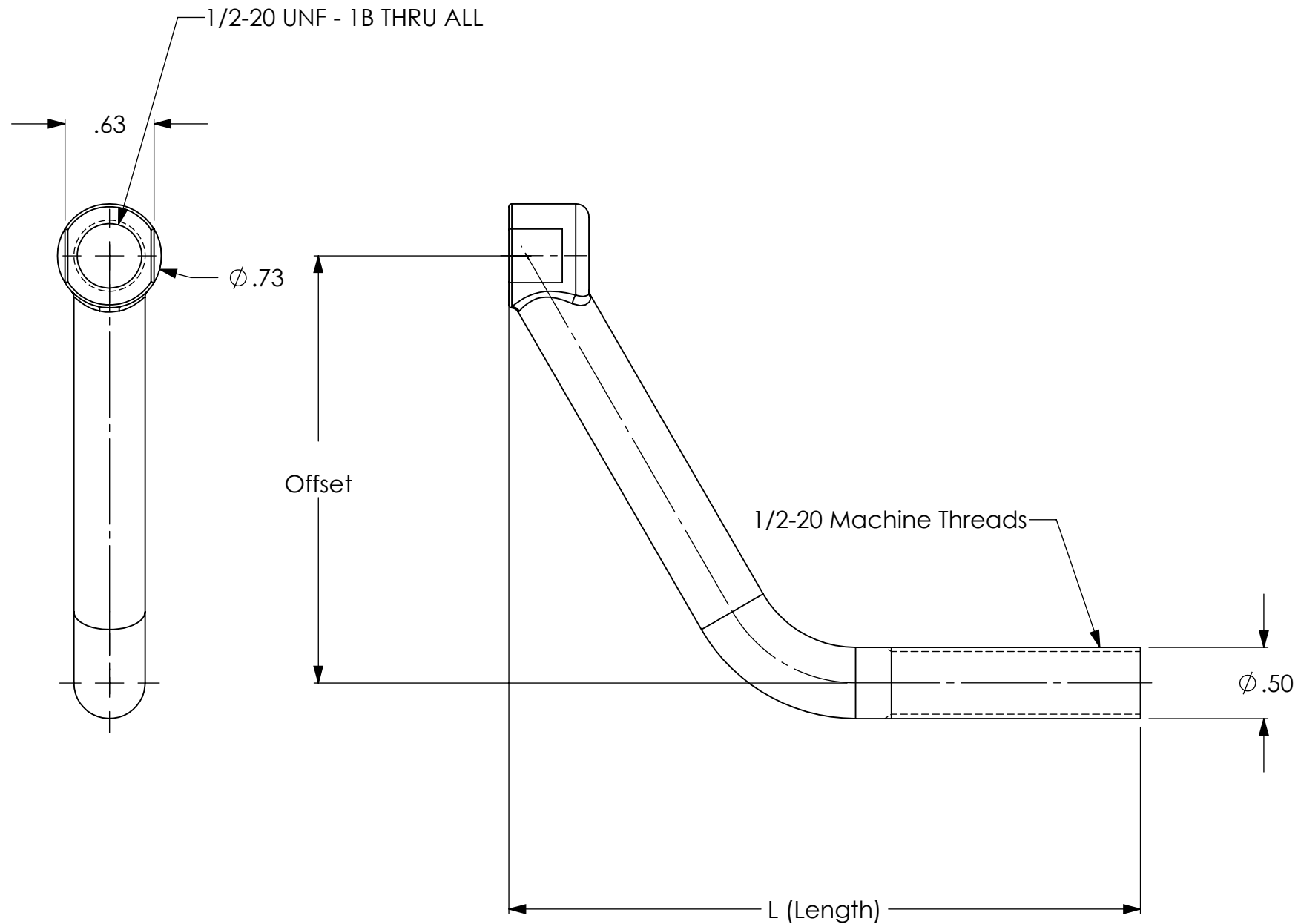

Part Number	O (Offset)	L (Length)
500109-15	1.50	3.57
500109-30	3.00	4.43
500109-45	4.50	5.30

DRAWING NOTES UNLESS OTHERWISE SPECIFIED  
 1. All dimensions are in inches.  
 2. Do not scale drawing.  
 3. Decimal Tolerance X.XX = +/- 0.01  
 4. Decimal Tolerance X.XXX = +/- 0.005  
 5. Fractional Tolerance X/X = +/- 1/16  
 6. Angle Tolerance: 0.5 degrees

APPROXIMATE WEIGHT (LBS)  
 0.44

THE INFORMATION CONTAINED IN THIS DRAWING IS THE SOLE PROPERTY OF FIRE PROGRAMS, LLC. ANY REPRODUCTION IN PART OR AS A WHOLE WITHOUT THE WRITTEN PERMISSION OF FIRE PROGRAMS, LLC IS PROHIBITED.

**FirePrograms**  
 SOFTWARE

6405 SW 38th St, Bldg 200  
 Ocala, FL 34474  
 Phone: 800.327.7638  
 www.fireprograms.com

TITLE  
**Rod Offset 0.5-20 M-F**

DRAWING NUMBER  
**500109**

REV  
**A**

SHEET SCALE  
 1:1

DATE  
 3/16/16

SHEET  
**1 OF 1**

REVISIONS		
REV.	DATE	DESCRIPTION
A	3/16/16	Initial Release