

NOTES:

1. MATERIAL: AISI 304 STAINLESS STEEL (PASSIVATED).

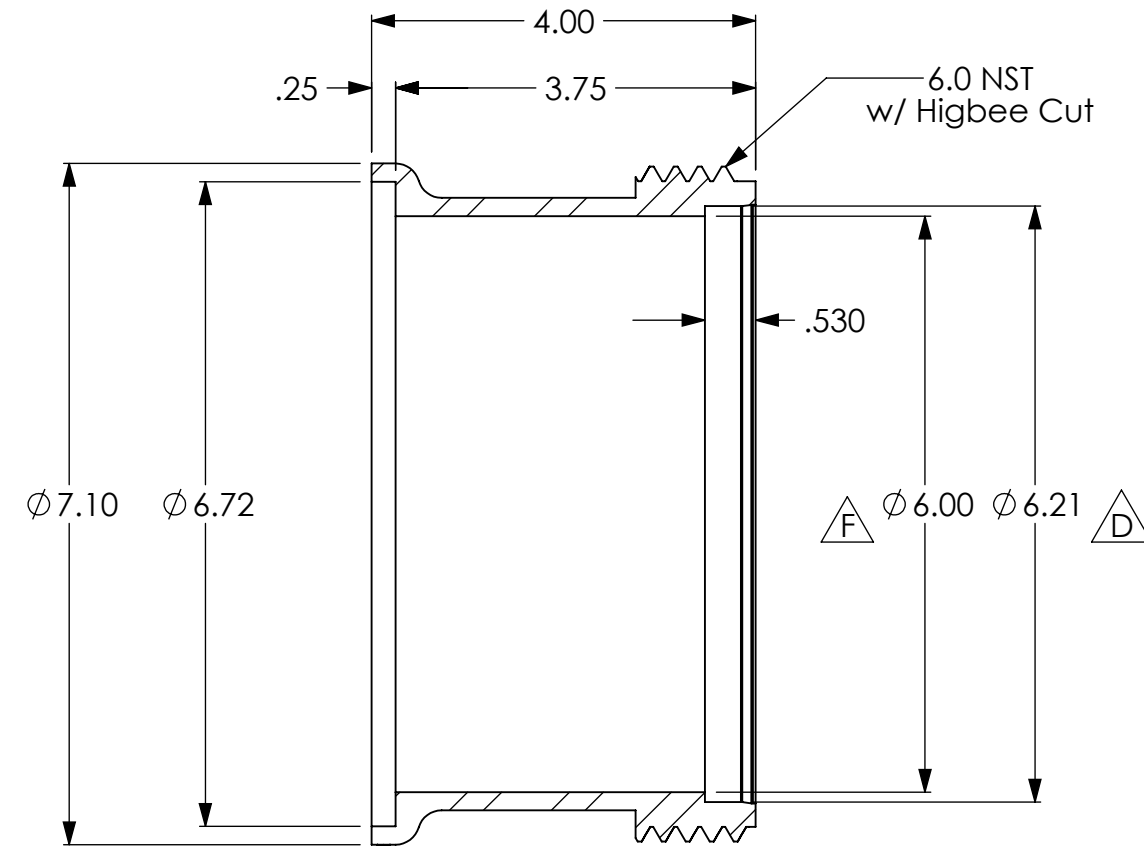
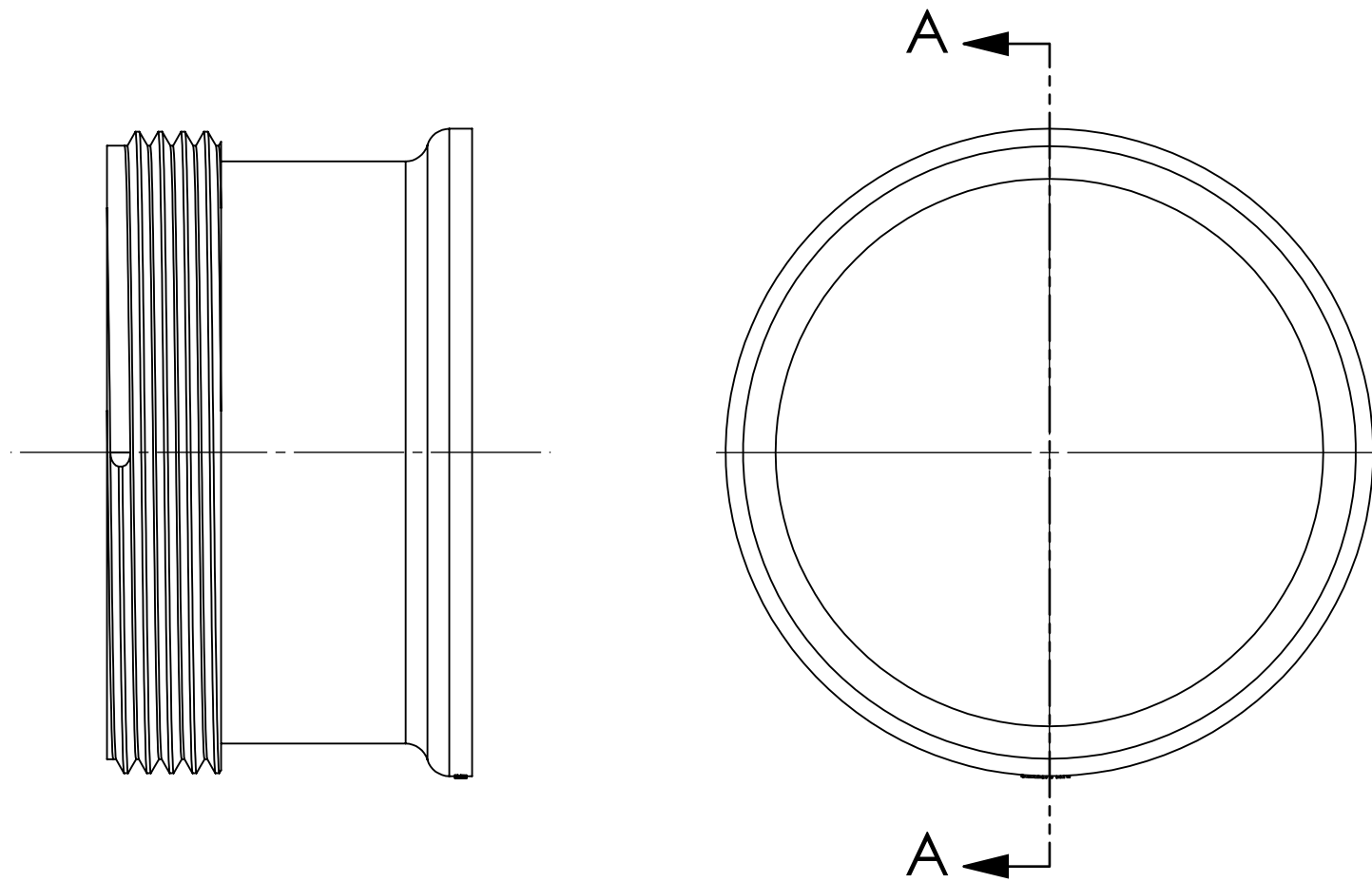
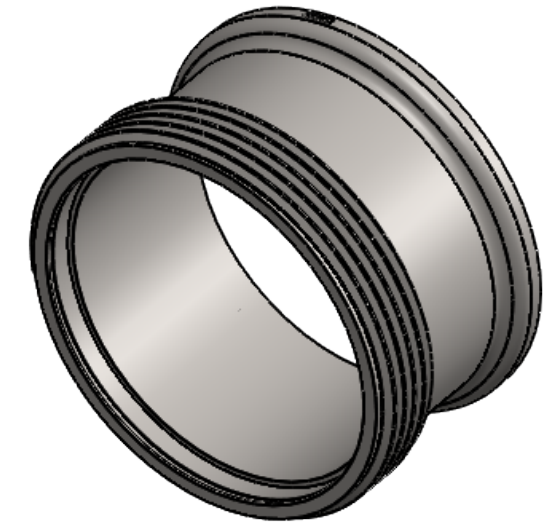

SECTION A-A

REVISIONS		
REV.	DATE	DESCRIPTION
A	2/25/16	Initial Release
B	7/10/2017	Increase depth of opening for strainer.
C	7/19/2017	Change diameter of opening for strainer.
D	8/8/2017	Change machining of opening for strainer.
F	8/6/2019	Changed inside diameter to straight through. Eliminated tabs and changed to weld bell.
F	1/31/2020	Reduced diameter of opening for strainer.

DRAWING NOTES UNLESS OTHERWISE SPECIFIED  
 1. All dimensions are in inches.  
 2. Do not scale drawing.  
 3. Decimal Tolerance X.XX = +/- 0.01  
 4. Decimal Tolerance X.XXX = +/- 0.005  
 5. Fractional Tolerance X/X = +/- 1/16  
 6. Angle Tolerance: 0.5 degrees

APPROXIMATE WEIGHT (LBS)  
**6.34**

THE INFORMATION CONTAINED IN THIS DRAWING IS THE SOLE PROPERTY OF FIRE PROGRAMS, LLC. ANY REPRODUCTION IN PART OR AS A WHOLE WITHOUT THE WRITTEN PERMISSION OF FIRE PROGRAMS, LLC IS PROHIBITED.

		6405 SW 38th St, Bldg 200 Ocala, FL 34474 Phone: 800.327.7638 www.fireprograms.com	
		TITLE <b>Cstg 6.0 NST x 6.0 WB</b>	
DRAWING NUMBER <b>500101</b>		REV F	SHEET SCALE 1:2
		DATE 1/31/2020	SHEET 1 OF 1