

NOTES:

1. STEEL WITH ZINC CHROMATE FINISH.

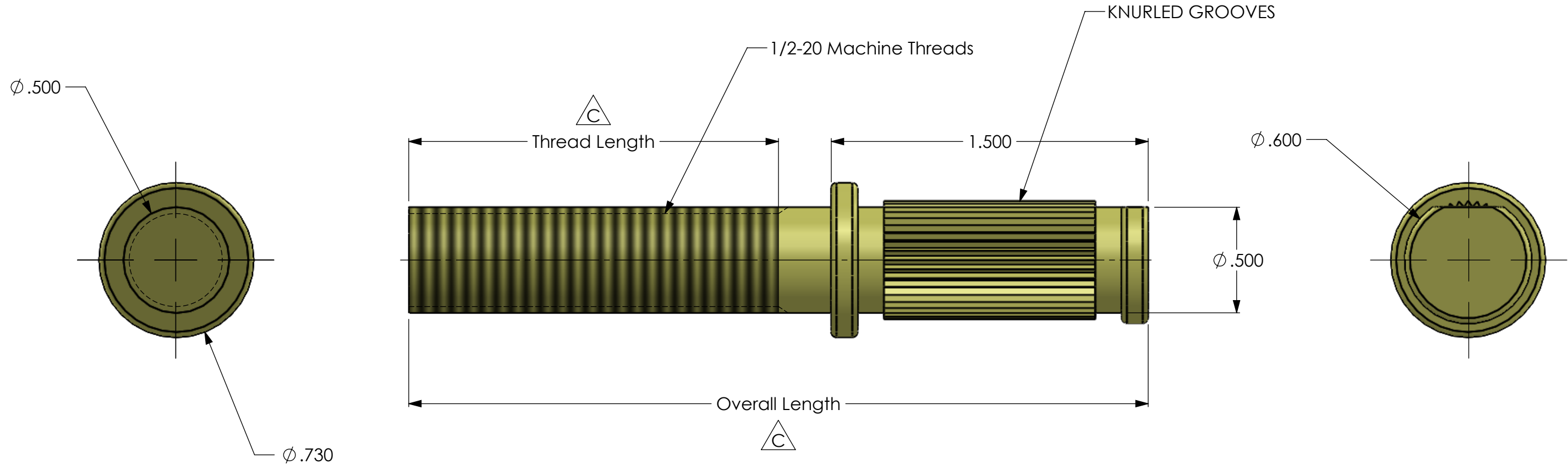
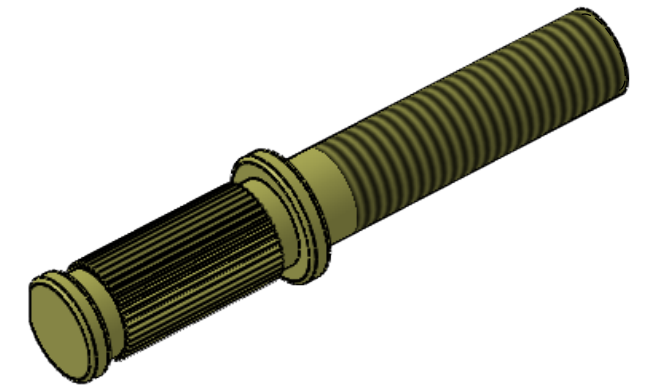

Part Number	Overall Length	Thread Length
500075	3.500	1.750
500075-275	4.500	2.750

REVISIONS		
REV.	DATE	DESCRIPTION
A	11/16/2015	Initial Release
B	11/9/2016	Remove material to provide clearance for pipe seam.
C	5/16/2017	Added 500075-275.

DRAWING NOTES UNLESS OTHERWISE SPECIFIED
 1. All dimensions are in inches.
 2. Do not scale drawing.
 3. Decimal Tolerance X.XX = +/- 0.01
 4. Decimal Tolerance X.XXX = +/- 0.005
 5. Fractional Tolerance X/X = +/- 1/16
 6. Angle Tolerance: 0.5 degrees

APPROXIMATE WEIGHT (LBS)

THE INFORMATION CONTAINED IN THIS DRAWING IS THE SOLE PROPERTY OF FIRE PROGRAMS, LLC. ANY REPRODUCTION IN PART OR AS A WHOLE WITHOUT THE WRITTEN PERMISSION OF FIRE PROGRAMS, LLC IS PROHIBITED.

	6405 SW 38th St, Bldg 200 Ocala, FL 34474 Phone: 800.327.7638 www.fireprograms.com	
	TITLE Rod End 0.50 Tube Crimp 0.50-20	
DRAWING NUMBER 500075	REV C	SHEET SCALE 1:0.5
	DATE 5/16/2017	SHEET 1 OF 1