

NOTES:

1. MATERIAL: AISI 304 STAINLESS STEEL (PASSIVATED).

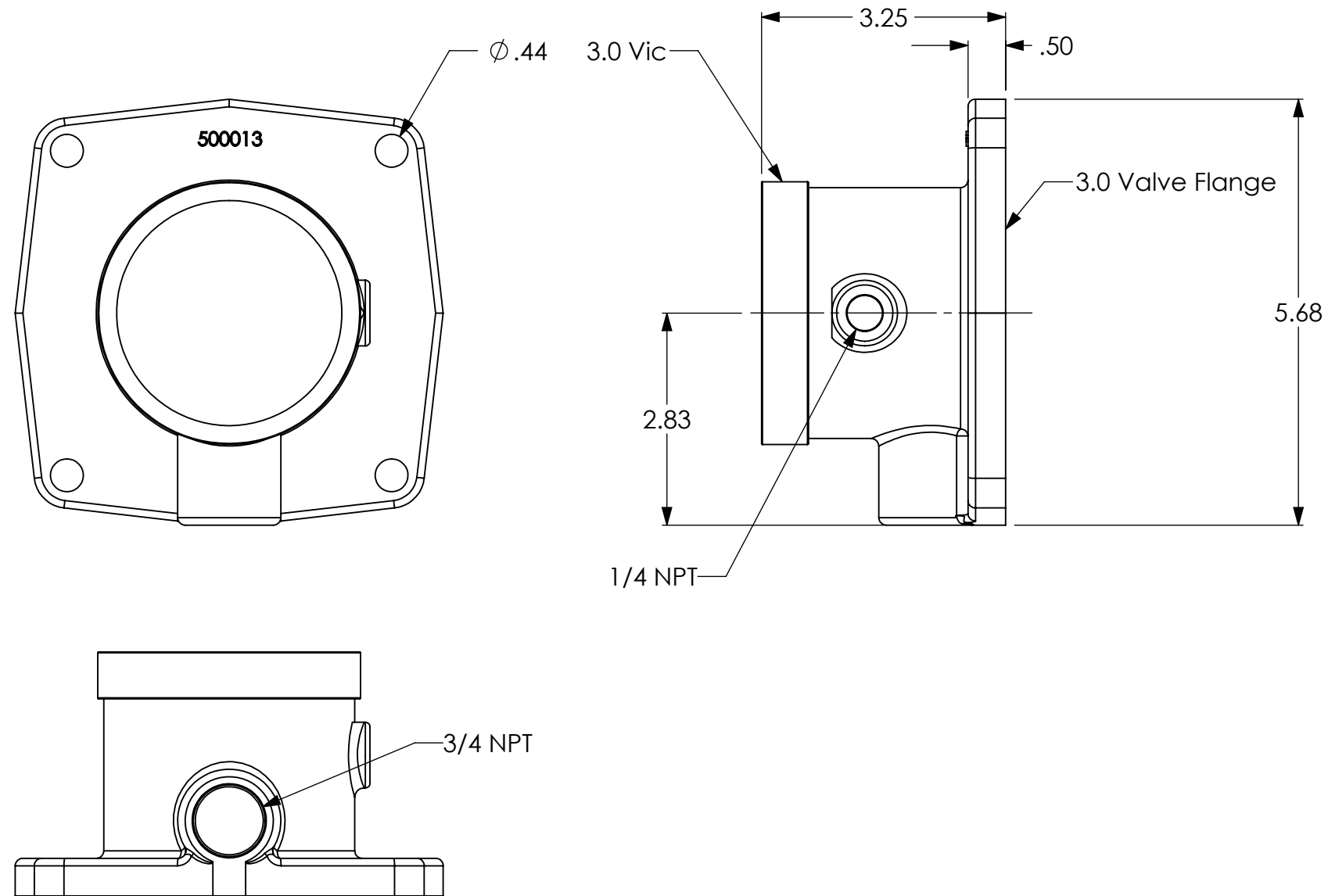
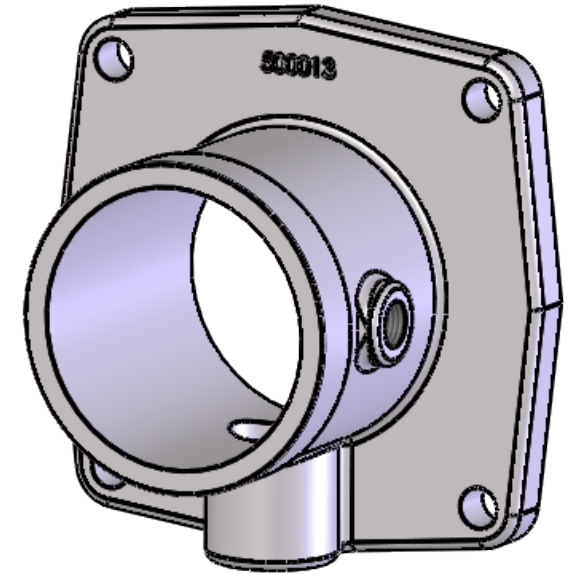

DRAWING NOTES UNLESS OTHERWISE SPECIFIED
 1. All dimensions are in inches.
 2. Do not scale drawing.
 3. Decimal Tolerance X.XX = +/- 0.01
 4. Decimal Tolerance X.XXX = +/- 0.005
 5. Fractional Tolerance X/X = +/- 1/16
 6. Angle Tolerance: 0.5 degrees

APPROXIMATE WEIGHT (LBS)
4.64

THE INFORMATION CONTAINED IN THIS DRAWING IS THE SOLE PROPERTY OF FIRE PROGRAMS, LLC. ANY REPRODUCTION IN PART OR AS A WHOLE WITHOUT THE WRITTEN PERMISSION OF FIRE PROGRAMS, LLC IS PROHIBITED.

FirePrograms
 6405 SW 38th St, Bldg 200
 Ocala, FL 34474
 Phone: 800.327.7638
 www.fireprograms.com

TITLE
Flange Vlv 3.0 x V w .75 Drain

DRAWING NUMBER
500013

REV
C

DATE
4/1/2015

SHEET SCALE
1:2

SHEET
1 OF 1

REVISIONS		
REV.	DATE	DESCRIPTION
A	11/16/2010	Initial Release
B	9/24/2013	
C	4/1/2015	