

NOTES:

1. MATERIAL: AISI 304 STAINLESS STEEL (PASSIVATED).

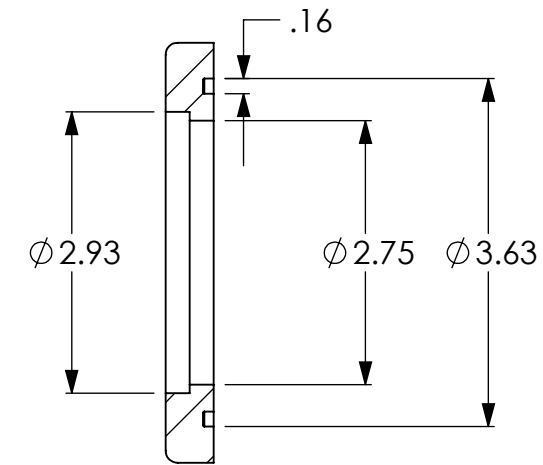
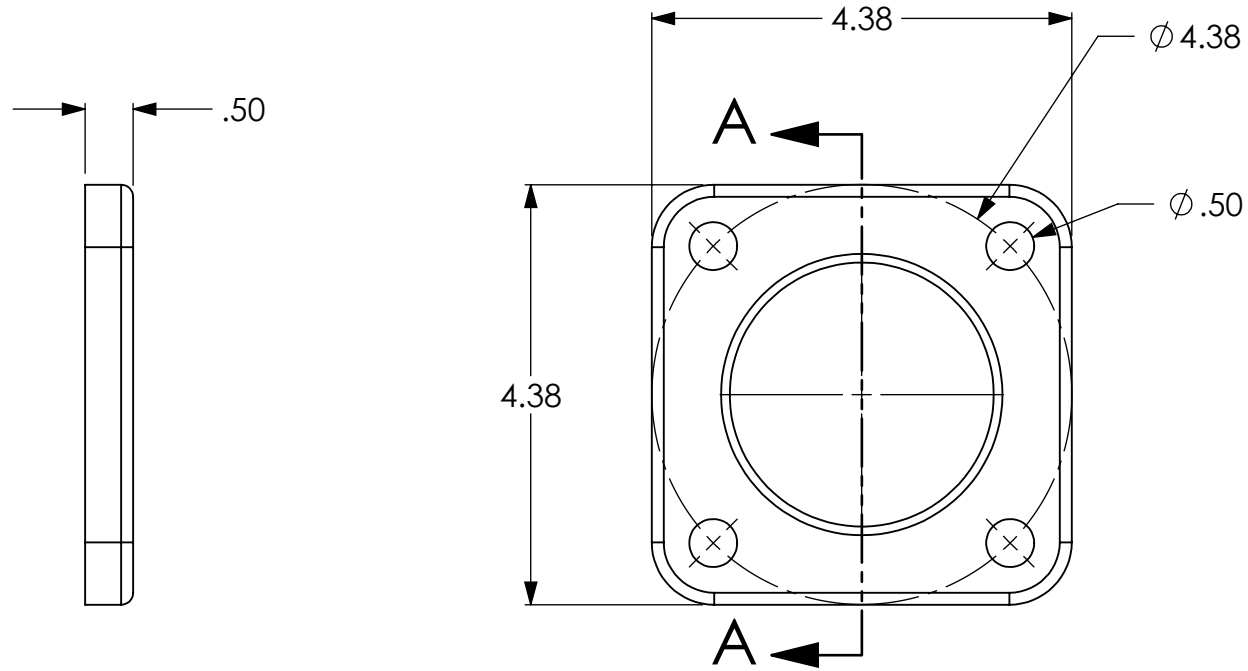
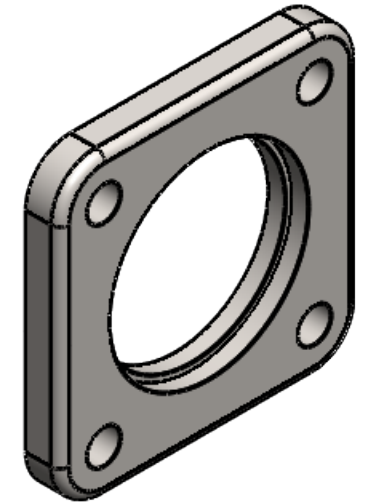

SECTION A-A

DRAWING NOTES UNLESS OTHERWISE SPECIFIED
 1. All dimensions are in inches.
 2. Do not scale drawing.
 3. Decimal Tolerance X.XX = +/- 0.01
 4. Decimal Tolerance X.XXX = +/- 0.005
 5. Fractional Tolerance X/X = +/- 1/16
 6. Angle Tolerance: 0.5 degrees

APPROXIMATE WEIGHT (LBS)
 1.55

THE INFORMATION CONTAINED IN THIS DRAWING IS THE SOLE PROPERTY OF FIRE PROGRAMS, LLC. ANY REPRODUCTION IN PART OR AS A WHOLE WITHOUT THE WRITTEN PERMISSION OF FIRE PROGRAMS, LLC IS PROHIBITED.

FirePrograms

6405 SW 38th St, Bldg 200
 Ocala, FL 34474
 Phone: 800.327.7638
 www.fireprograms.com

TITLE
Cstg Flange 115 x 2.0 or 2.5 Weld

DRAWING NUMBER
500008

| | |
|------------------|--------------------|
| REV A-01 | SHEET SCALE 1:2 |
| DATE 4/4/2011 | SHEET 1 OF 1 |

| REVISIONS | | |
|-----------|----------|-----------------|
| REV. | DATE | DESCRIPTION |
| A | 4/4/2011 | Initial Release |